

REVISIONS		
ISS	ZONE	DESCRIPTION\PER REQUEST\DATE

注意事項	
1	包裝方式: 1000/包

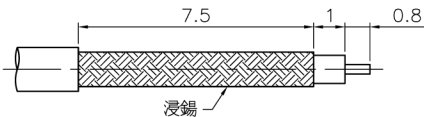

RECOMMENDED
CABLE STRIPPING DIM'S
(建議剝線尺寸)

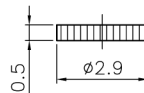
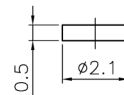
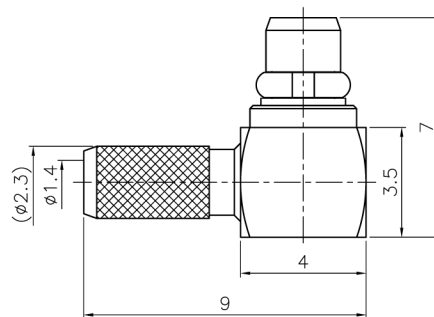

1. CONTACT PIN AND BARREL TO SOLDER

TYPICAL SPECIFICATIONS

1.0. ELECTRICAL

- 1.1. FREQUENCY RANGE: DC-6 GHz
- 1.2. NOMINAL IMPEDANCE: 50 OHM
- 1.3. WORKING VOLTAGE: 85 VOLTS MAX.
- 1.4. PROOF VOLTAGE: 250 VOLTS
- 1.5. VSWR: 1.3 MAX. @ 3 GHz

2.0. MATERIALS

- 2.1. BODIES: BRASS PER JIS-C3604
- 2.2. CENTER CONTACT: BRASS PER JIS-C3604
- 2.3. INSULATION: PTFE PER ASTM D1457 AND ASTM D1710
- 2.4. RING: BERYLLIUM COPPER PER ASTM B196 UNS C17200

3.0. ENVIRONMENTAL

- 3.1. OPERATING TEMPERATURE RANGE: -55° C TO +155° C

7	COVER	BRASS	GOLD	1	CV-29X05G
6	INSULATOR	POM	NATURAL	1	NS-21X05D
5	CONTACT PIN	BRASS	GOLD	1	MMCX1122A1-5-1/05G
4	RING	BE CU	GOLD	1	MMCX1121A1-4BEG
3	BODY	BRASS	GOLD	1	MMCX1122A1-3G
2	INSULATOR	PTFE	WHITE	1	MMCX1122A1-2T-50
1	BARREL	BRASS	GOLD	1	MMCX1122A2-1-23/14G
NO.	DESCRIPTION	MATERIAL	FINISH	Q'TY	DRAWING NO.

DIMENSIONS ARE IN MILLIMETERS

UNLESS OTHERWISE SPECIFIED TOLERANCES

ANGLES = ±3'
UP TO 6 = ±0.1
6-40 = ±0.2
40-120 = ±0.6
120-315 = ±1
ABOVE 315 = ±1.6

SCALE/比例 6/1

DATE/時間 05-20-12

APPROVED/核准

MARK

CHECKED/檢查

MARK

DRAWN/繪圖

MARK

FILE NO. F:\CAD\MMCX\1122A2\50\GTG-1.37-A#

JAWDropper Innovation Channel Co., Ltd.	
TITLE/品名 MMCX R/A PLUG (1.32mm, 1.37mm)	
DRAWING NO./圖號 MMCX1122A2-GTG-1.37-50	REV A
CUSTOMER NO./客戶編號	REV