

REVISIONS		
ISS	ZONE	DESCRIPTION\PER REQUEST\DATE

注意事項	
1	包裝方式: 1000/包

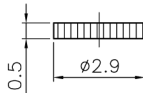
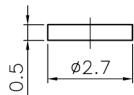
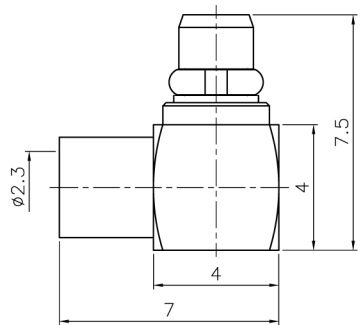
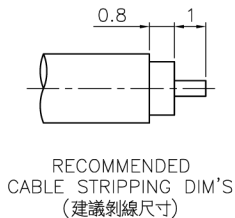

TYPICAL SPECIFICATIONS

1.0 ELECTRICAL

- 1.1. FREQUENCY RANGE: DC-6 GHz
- 1.2. NOMINAL IMPEDANCE: 50 OHM
- 1.3. WORKING VOLTAGE: 170 VOLTS MAX.
- 1.4. PROOF VOLTAGE: 500 VOLTS
- 1.5. VSWR: 1.3 MAX. @ 3 GHz

2.0 MATERIALS

- 2.1. BODIES: BRASS PER JIS-C3604
- 2.2. CENTER CONTACT: BRASS PER JIS-C3604
- 2.3. INSULATION: PTFE PER ASTM D1457 AND ASTM D1710
- 2.4. RING: BERYLLIUM COPPER PER ASTM B196 UNS C17200

3.0 ENVIRONMENTAL

- 3.1. OPERATING TEMPERATURE RANGE: -55° C TO +155° C

1. CONTACT PIN AND BARREL TO SOLDER

7	COVER	BRASS	GOLD	1	CV-29X05G
6	INSULATOR	POM	NATURAL	1	NS-27X05D
5	CONTACT PIN	BRASS	GOLD	1	MMCX1122B1-5-12/07G
4	RING	BE CU	GOLD	1	MMCX1121A1-4BEG
3	BODY	BRASS	GOLD	1	MMCX1122B1-3G
2	INSULATOR	PTFE	WHITE	1	MMCX1122A1-2T-50
1	BARREL	BRASS	GOLD	1	MMCX1182B1-1-32/23G
NO.	DESCRIPTION	MATERIAL	FINISH	Q'TY	DRAWING NO.

DIMENSIONS ARE IN MILLIMETERS	
UNLESS OTHERWISE SPECIFIED TOLERANCES	
ANGLES = ±3'	
UP TO 6 = ±0.1	
6-40 = ±0.2	
40-120 = ±0.6	
120-315 = ±1	
ABOVE 315 = ±1.6	
SCALE/比例	6/1
DATE/時間	05-20-12

APPROVED/核准
MARK
CHECKED/檢查
MARK
DRAWN/繪圖
MARK
FILE NO. F:\CAD\MMCX\1182B1\50\GTG-405U-A#

 Innovation Channel Co., Ltd.	
TITLE/品名	MMCX R/A SEMI-RIGID PLUG (.085")
DRAWING NO./圖號	MMCX1182B1-GTG-405U-50
CUSTOMER NO./客戶編號	
REV	A
REV	